

Application Packet for Access Permit

Town of Pacific, Columbia County, WI

W7530 HWY 16, Pardeeville, WI 53954

Included in this Packet:

- Summary of Application Process
- Agreement for Reimbursable Services
- Application For Access Permit
- Application Submittal Checklist
- Access Design Standards
- Sample Site Plan
- Qualified Contractor Certification Application

The purpose of this document is to provide guidance to an applicant applying for an Access Permit in the Town of Pacific.

Summary of Application Process

1. Contact the Town Clerk to obtain an Application for Access Permit Packet in electronic form, or obtain the form at www.tn.pacific.wi.gov
2. Contact the Town Engineer for initial direction and guidance on the driveway/application. Depending on your project the Town Engineer may be able to provide guidance that will aid you in filling out the application, and save you time and money over the course of the permitting process. You may obtain the Town Engineer's contact information on the Town's website at www.tn.pacific.wi.gov or from the Town Clerk.
3. Pay Application Fee Directly to the Town Clerk at the office of the Town Hall. You may obtain the current fee by viewing the Town's Fee Schedule at the Town's website.
4. Fill out all forms in the Packet completely. Include a detailed Site Plan and any supporting documentation that is requested by the Town Engineer. The Town Engineer will work with you to make sure that you have all of the appropriate information for your submittal.
5. The Applicant shall submit to the Clerk an electronic copy of the Application, and all associated documents being submitted as part of the Application, in PDF format, along with one (1) comprehensive copy in printed form, identical to the electronic copy in all respects. The Application Fee shall accompany the Application.

EACH PACKET SHALL CONTAIN THE FOLLOWING:
<ul style="list-style-type: none"><input type="checkbox"/> Reimbursable Services Agreement<input type="checkbox"/> Completed Application For Access Permit Form<input type="checkbox"/> Completed Application Submittal Checklist<input type="checkbox"/> Detailed Site Plan, and all items outlined in the Application Submittal Checklist<input type="checkbox"/> Copy of Selected Qualified Contractor Certification or Application<input type="checkbox"/> Application Fee payable to "Town of Pacific"

5. The Town Engineer shall review all of the submitted documents and determine the completeness of the application and shall approve, conditionally approve or deny the Application. A site visit or site meeting may be deemed necessary by the Town Engineer to review the site, drainage and roadway conditions. If denied, the Applicant shall be entitled to appeal as provided in Chapter 345 of the Town of Pacific's Code.
6. Applications will not be processed without payment of all fees (see Town's Fee Schedule).

Agreement for Reimbursable Services

Re: (Project Name): _____

The fees & costs of application review for the following permit request(s) shall be paid by the Applicant:

The Applicant shall pay all reasonable Town of Pacific incurred expenses relating to a particular permit request. Applicant agrees to reimburse the Town of Pacific for all review costs associated with, but not limited to, the Town Engineer and Town Attorney, in connection with the permit request and, further, agrees to reimburse the Town for other administrative staff review if, in the judgment of the Town Board, such reimbursement is warranted. This may also include meeting charges, professional consultants, and other relevant Town expenses incurred in connection to the permit request. The Town reserves the right to apply the charges for these services as well as for staff time, mileage, and Town equipment usage expended in the administration, investigation and processing of applications to the Applicant. Review fees owed by the Applicant, which are not paid within thirty (30) days of the issuance of an invoice by the Town, shall accrue interest at a rate of 1.5% per month, until the fee is paid in full.

If the Applicant is not the owner, then the owner agrees to pay all review fees and expenses that are not timely paid by Applicant. If unpaid, the Town may collect such delinquent fees and expenses as a special charge on owner's real estate under §66.0627 Wis. Stats., or from applicant or owner, through other means provided by law. Further, the Town may withdraw or suspend any permit issued by the Town, if any fees or expenses relating to that permit, have not been timely paid.

The Applicant is required to provide the Town with an executed copy of this Agreement as a prerequisite to the processing of the permit request application.

Dated this _____ day of _____, 20____ .

Signature of Applicant

Printed Name

Signature of Property Owner
(If Different From Applicant)

Printed Name

This form is to be used for any Application for which the Town is to receive reimbursement for review fees and costs, EXCEPT projects for which a Pre-Development Agreement is to be signed.

Application for Access Permit

GENERAL INFORMATION			
Property Owner(s):			
Mailing Address:	City:	State:	Zip Code:
Phone Number (Days):	Phone Number (Cell):	Email Address:	
Contractor:	Sub-contractor:	Authorized Representative:	
Mailing Address:	City:	State:	Zip Code:
Phone Number:	Email Address:	Town of Pacific QCC Approval? If yes, provide year(s) of approval:	

DESCRIPTION OF PROPERTY			
Address of Subject Property:	City:	State:	Zip Code:
Tax Parcel #:	Subdivision:	Lot#:	Block:
Names of Adjacent Roadways:			
Adjacent Parcels (Parcel # or Addresses):			
Proposed Use of Facilities:	Start Date:	Completion Date:	
Project Specifications and other project information: Type of Driveway: Approximate Ditch Depth Culvert Type: Pipe Bedding: Culvert Length: Endwalls Driveway Width at Culvert: (Attach any additional information).			
If your Access Application involves work within the Town right-of-way, then submit a Qualified Contractor Certification or Application for Qualified Contractor Certification, covering the contractor who will perform this Work. <input type="checkbox"/> N/A (does not involve work in Town right-of-way) <input type="checkbox"/> Certification or Application Attached			
You have received Chapter 345 of the Town of Pacific Ordinances and understand the General Provisions for driveways and access points onto Town Roads.			<input type="checkbox"/> YES
NOTICE: Town of Pacific roads are to be maintained throughout all construction in the right-of-way. If a road or ditchline is damaged as a result of any activity related to this Permit, the Town of Pacific will repair the damage and charge the cost on the Permittee.			
Are any State/Federal Permits for this project being applied for? <input type="checkbox"/> YES <input type="checkbox"/> NO			
Check All that Apply: <input type="checkbox"/> WI DOT <input type="checkbox"/> WI DNR <input type="checkbox"/> WI DOC <input type="checkbox"/> US Army Corps <input type="checkbox"/> Other _____			

Signature of Owner

Printed Name

Date

Signature of General Contractor

Printed Name

Date

Application Submittal Checklist

- Paid Application Fee
- Photographs of the affected area
- Qualified Contractor Certification or Application
- Erosion Control provisions for the work (see the Town's Erosion Ordinance)
- A Site Plan, with a reasonable degree of accuracy. Please show the following on the drawing:
 - North Arrow
 - Existing Site Features
 - Neighboring Features
 - Proposed facilities – including house footprint, driveway configuration & type, driveway width, culvert size, culvert length, culvert type, endwalls & type, and drainage flow direction.

(The Town, at its discretion, may require this drawing to be prepared by a surveyor or engineer.)

Signature of Owner or Homeowner

Printed Name

Date

Signature of General Contractor

Printed Name

Date

Incomplete, inaccurate, or non-submittal of any of the above items may be grounds for rejection of the application, or denial of the request.

ACCESS DESIGN STANDARDS

TOWN OF PACIFIC-COLUMBIA COUNTY, WI

- TYPE "A" ACCESS:** PRIVATE DRIVEWAYS WITH ACCESS TO ONE OR TWO AGRICULTURAL OR RESIDENTIAL PARCELS
- TYPE "B" ACCESS:** MUST BE USED FOR RESIDENTIAL WITH 3-20 UNITS, AND COMMERCIAL OR INDUSTRIAL WITH UP TO 25,000 SQUARE FEET.
- TYPE "C" ACCESS:** MUST BE USED FOR RESIDENTIAL WITH OVER 20 UNITS, AND COMMERCIAL OR INDUSTRIAL OVER 25,000 SQUARE FEET.

TYPE "A" ACCESS

KEY

- 1A=20'
- 2A=20'
- 3A=20'-24'
- 4A=24'

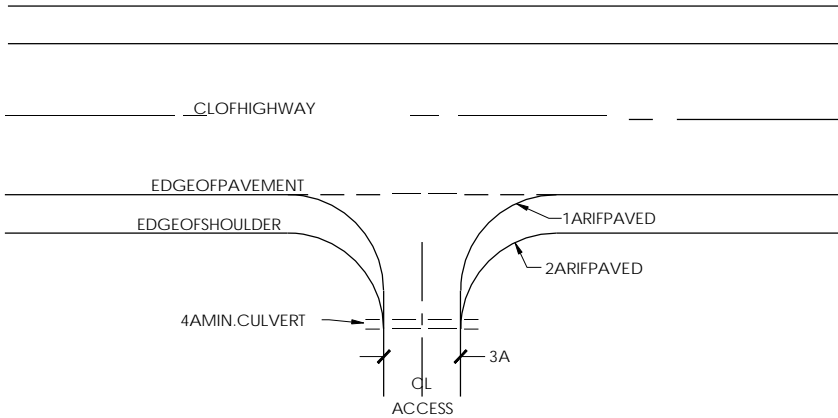

TYPE "B" ACCESS

KEY

- 1B=150'
- 2B=100'
- 3B=150'
- 4B=200'
- 5B=12'
- 6B=12'
- 7B=40'
- 8B=60'
- 9B=150'
- 10B=24'-35'
- 11B=100'

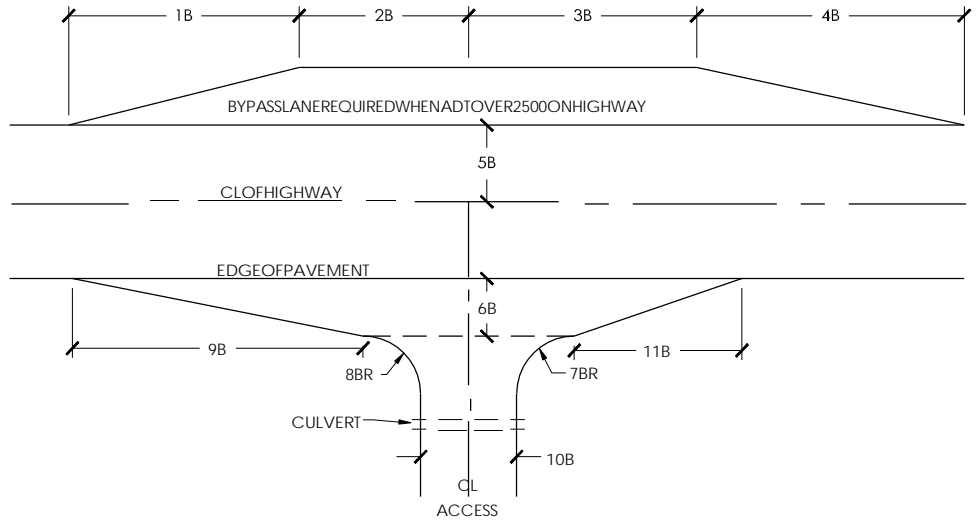

TYPE "C" ACCESS

KEY

- 1C=150'
- 2C=100'
- 3C=150'
- 4C=200'
- 5C=12'
- 6C=12'
- 7C=150'
- 8C=50'
- 9C=60'
- 10C=40'
- 11C=100'
- 12C=24'-35'

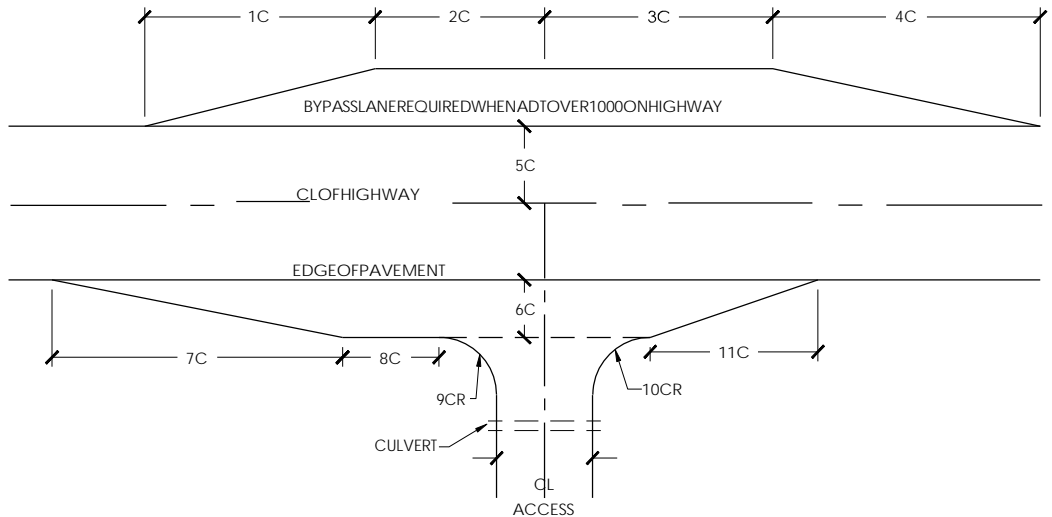

Application for Qualified Contractor Certification

APPLICANT INFORMATION			
Name of Company:		Chief Officer or Manager:	
Mailing Address:	City:	State:	Zip Code:
Phone Number:	Fax Number:	Email Address:	
Are you renewing your Qualified Contractor Certification? <input type="checkbox"/> NO <input type="checkbox"/> YES > YEAR QCC APPROVED: _____ Are you a Sub-Contractor seeking a QCC? <input type="checkbox"/> YES <input type="checkbox"/> NO > Name of General Contractor: _____			

CERTIFICATION CHECKLIST	
When did Company begin business? Year: _____	
Form of business entity: Sole Proprietorship/Partnership/LLC, Corporation	
List number of years company has been doing business in roadwork, pipework, excavation or finish restoration:	_____ years
Attach a list all current licenses, registrations and certifications held for excavation, utility work or roadway work:	<input type="checkbox"/> Information Attached
Attach the background/experience for your company for contracting work you perform – OR; I am renewing my Qualified Contractor Certification with no updates.	<input type="checkbox"/> Information Attached <input type="checkbox"/> Renewal
Attach a list of your major equipment used on projects – OR; I am renewing my Qualified Contractor Certification with no updates.	<input type="checkbox"/> Information Attached <input type="checkbox"/> Renewal
List insurance coverage. Attach insurance certificates for workers compensation, general & pollution liability, etc. – OR; I am renewing my Qualified Contractor Certification with no updates.	<input type="checkbox"/> Information Attached <input type="checkbox"/> Renewal
Attach a list of bonding coverage if any. Include limit of payment.	<input type="checkbox"/> Information Attached
Has your firm had any type of business, contracting or trade license, certification or registration revoked or suspended in the past five years?	<input type="checkbox"/> Yes – Attach Details <input type="checkbox"/> No
Has your firm violated any safety rules or regulations as determined by OSHA during the last five (5) years?	<input type="checkbox"/> Yes -- Attach Details <input type="checkbox"/> No
Indicate which of the following you have at least five (5) years of relevant construction work experience with:	
<input type="checkbox"/> Driveway construction or alteration	<input type="checkbox"/> Ditching or grading in the right-of-way
<input type="checkbox"/> Roadwork, including gravel base, asphalt or concrete, guardrails and shouldering	<input type="checkbox"/> Utility work, including CATV, Telephone, Fiber Optic, Electric, Gas, etc.
<input type="checkbox"/> Tree or Brush Clearing	<input type="checkbox"/> Turf, Shoulder & Asphalt Restoration
	<input type="checkbox"/> Pipe and culvert installation
	<input type="checkbox"/> Subdivision infrastructure improvement projects

Town of Pacific

Columbia County, WI

Mailing Address:
 W7530 Hwy 16
 Pardeeville, WI 53954
www.tn.pacific.wi.gov

Attach the general quality control practices your firm utilizes, including information on supervision of projects – OR; I am renewing my Qualified Contractor Certification with no updates.	<input type="checkbox"/> Information Attached <input type="checkbox"/> Renewal
Provide at least two municipal references – OR; I am renewing my Qualified Contractor Certification with no updates.	<input type="checkbox"/> Information Attached <input type="checkbox"/> Renewal
Have you worked on any projects in the Town of Pacific within the last five (5) years? - OR; I am renewing my Qualified Contractor Certification with no updates.	<input type="checkbox"/> Yes – Attach Details <input type="checkbox"/> Renewal

As a condition to the granting of this Application, the Applicant hereby agrees to be responsible for all damages relating in any way to its work within the boundaries' of any Town road, easement or other public facility. Applicant certifies, to the best of its knowledge and belief, all of the information contained in this application is correct. Applicant understands that the failure to report completely and accurately will result in the denial or withdrawal of the certification and loss of the application fee.

 Signature of Applicant's Chief Officer/Manager

 Printed Name

 Date

 Title

The application fee must accompany this Qualified Contractor Certification request. Current fees are posted at the Pacific Town Hall, and may periodically change.

Current fees may also be viewed at <http://www.tn.pacific.wi.gov/>